

# miniRaman Spectrometer



## User Manual

Version 001

**For Technical Support**, please contact:

**Lightnovo ApS**

Blokken 11, 1.

3460 Birkerød

Denmark

Phone: +45 71465729

<https://lightnovo.com/>

[service@lightnovo.com](mailto:service@lightnovo.com)

**For International Support**, please contact your local distributor.

Lightnovo ApS provides this document to its customers with a product purchase to use in the product operation. This document is copyright protected and any reproduction of the whole or any part of this document is strictly prohibited, except with the written authorization of Lightnovo ApS.

All technical information in this document is for reference purposes only. The contents of this document are subject to change without notice.

Lightnovo ApS makes no representations that this document is complete, accurate or error-free and assumes no responsibility and will not be liable for any errors, omissions, damage or loss that might result from any use of this document, even if the information in the document is followed properly.

For Research Use Only. This instrument or accessory is not a medical device and is not intended to be used for the prevention, diagnosis, treatment or cure of disease.

© 2026 Lightnovo Aps. All rights reserved.

# Contents

<b>Contents</b> .....	<b>3</b>
<b>Overview</b> .....	<b>4</b>
Instrument description .....	4
General specifications .....	5
Configuration options .....	5
Application of use .....	6
<b>Safety information</b> .....	<b>7</b>
Qualified Personnel .....	7
Warning labels .....	7
Warning label positions .....	8
Safety .....	8
General instrument information.....	9
Safety Instructions .....	9
<b>Installation</b> .....	<b>10</b>
Scope of Delivery .....	10
Standard Components .....	10
Inspecting the Packaging .....	10
Transportation .....	10
Site requirements .....	11
Accessories .....	11
Software installation .....	13
<b>Operation</b> .....	<b>14</b>
Attaching & removing probes.....	14
Standalone operation .....	15
LED guide.....	18
Hardware connection.....	19
<b>Technical drawings</b> .....	<b>21</b>
<b>Service</b> .....	<b>22</b>
Recommended care .....	22
Addresses .....	22

## Overview

The miniRaman Spectrometer is an innovative, miniaturized Raman spectrometer equipped with a patented, integrated reference channel. This innovative technology ensures automatic calibration by correcting for laser wavelength drift. The integrated reference channel continuously adjusts the Raman shift and intensity of the sample spectrum, delivering fast, accurate, and reliable results. These advanced features make the miniRaman spectrometer an ideal solution for material identification and precise quantitative measurements.

## Instrument description

The miniRaman spectrometer is a compact handheld Raman spectrometer. Physical dimensions of the spectrometer are approximately 105 x 50 x 45 mm and the weight is approximately 360g. The instrument has one optical port on the top for laser excitation and Raman signal collection. The instrument has a USB-C port on the bottom for charging and communication. The instrument has a LCD display and one button on the front for instrument operation.



LCD display



warning labels



optical port



USB C port

**Figure 1.** Front, back, top and bottom view of miniRaman spectrometer

## General specifications

**Table 1.** Typical values for the specifications of the miniRaman.

Feature versus model	miniRaman Standard	miniRaman SERS	miniRaman Dual	miniRaman Full Range	miniRaman Full Range SERS
Laser wavelength	785 nm		660 nm and 785 nm	660 nm	660 nm
Power on sample*	5-50 mW	1-15 mW	5-45 mW (660) 5-50 mW (785)	10-80 mW	1-15 mW
Spectral Range	270-3100 cm <sup>-1</sup>		2700-3700 cm <sup>-1</sup> (660) 300-2500 cm <sup>-1</sup> (785)	270-3700 cm <sup>-1</sup>	270-3700 cm <sup>-1</sup>
Spectral Resolution**	7,9,12 cm <sup>-1</sup>		11,14,18 cm <sup>-1</sup> (660) 7,9,12 cm <sup>-1</sup> (785)	11,14,17 cm <sup>-1</sup>	11,14,17 cm <sup>-1</sup>
Signal-to-noise ratio***	500:1	100:1	600:1 (660) 500:1 (785)	500:1	100:1

\* Actual laser power range can differ  $\pm 5\%$  per device. Please contact us if you need specific laser power range values. Lower limit requires exposure time of 2 seconds.

\*\* Slit size dependent; slit size can be customized (20,35,50  $\mu\text{m}$  slits).

\*\*\* Determined as peak signal-to-noise ratio of polystyrene spectrum at maximum laser power, integration time of 0.3s, number of repetitions of 10.

## Configuration options

### Slit sizes

The spectrometer's slit can be 1 of 3 sizes. By default, 35  $\mu\text{m}$  slit width is installed. Either a 20  $\mu\text{m}$  or 50  $\mu\text{m}$  slit width can be installed to improve the resolution or the throughput respectively, at the expense of the other parameter.

### Operator

The configuration adds water and dust proofing, as well as drop resistance to the instrument.

### Power

The Power configuration installs a higher powered laser into the spectrometer.

### SERS

The SERS configuration reduces the laser's power minimum value to  $\sim 1$  mW, so that when used with a 100x objective, the laser power density is below 1 mW/ $\mu\text{m}^2$ .

### Configuration matrix

The following table explains which configuration options are compatible with which laser versions on the miniRaman spectrometer.

**Table 2.** Configuration options

	600 nm	785 nm	Dual
<b>Operator</b>	Yes	Yes	Yes
<b>Power</b>	No	Yes*	No
<b>SERS</b>	Yes	Yes	No
<b>20 µm slit</b>	Yes	Yes	Yes
<b>50 µm slit</b>	Yes	Yes	Yes

\* Power configuration available for miniRaman 785, with maxpower up to 70 mW

## Application of use

The miniRaman spectrometer is a general purpose handheld Raman analysis instrument for qualitative and semi-quantitative analysis of liquids and solids. It is intended for laboratory, industrial and field environments. Raman spectroscopy is non-destructive technique and can be performed without contact with the sample. This instrument can be used for identification, verification, and screening of a wide variety of samples, using onboard library searching. Semi-quantitative and quantitative measurements can be performed using chemometric analysis on Lightnovo's computer software, Miraspec Flow.

### Note



In Raman spectroscopy, sample fluorescence can yield a much more intense signal than the Raman scattering signal of the sample, masking any Raman bands in the spectrum. Therefore, Raman spectroscopy is normally not a suitable analysis technique for fluorescent samples.

## Safety information

Read the following safety information carefully before operating the Lightnovo instrument and keep this manual for future reference available at any time. Always follow the instructions described in this manual to ensure safe operation and to avoid property damage. Improper use or failure to follow these safety instructions can result in serious injuries and/or property damage. Any non-observance of the precautions will infringe the intended use (i.e. performing measurements by Raman spectroscopy) of the instrument. In this case Lightnovo ApS will not assume any liability. It is the operator's duty to plan and implement all necessary safety measures and to supervise their observance. Moreover, the operator must ensure that the instrument is in proper functioning condition. A safe and faultless operation can only be guaranteed if the Lightnovo instrument is transported, stored, installed, operated and maintained properly according to the procedures described in this manual. Never remove or deactivate any safety systems during the instrument's operation. Ensure that objects and/or material not required for the measurement is out of the instrument operating area.

## Qualified Personnel

Primary installation, maintenance and repair works not described in this manual should only be performed by Lightnovo approved service personnel. Only authorized operating personnel that have been briefed about the instrument operation and all relevant safety aspects should operate and maintain (i.e. only maintenance works that are described in this manual) the instrument. It is the duty of the instrument owner to ensure users have proper training for use of a laser device and relevant risk assessments are in place. All repairs, adjustments and alignments on any instrument component must be performed in accordance with the safety regulations and standards applied in the country in which the instrument is installed.

## Warning labels

This warning symbol indicates the existence of laser radiation.



Class 3B lasers are hazardous for eye exposure. They can heat skin and materials but are not considered a burn hazard. For visible-light lasers, Class 3B lasers' output power is between 5 and 499 milliwatts. Class 3B lasers are normally hazardous under direct beam viewing conditions, but are normally safe when viewing diffuse reflections.

## Warning label positions



**Figure 2.** Back and bottom view of miniRaman spectrometer

## Safety

The following chapters describe all relevant safety aspects of the instrument operation. Depending on the degree of hazard the safety instructions are classified as follows:



### **Danger**

indicates that death, severe personal injury or substantial property damage WILL result if proper precautions are not taken.



### **Warning**

indicates that death, severe personal injury or substantial property damage CAN result if proper precautions are not taken.



### **Caution**

indicates that minor personal injury or property damage CAN result if proper precautions are not taken. Important draws your attention to a particularly important information.



### **Note**

draws your attention to useful information on the product, e.g. product operation or to a special part of the manual.

The safety instructions Danger, Warning and Caution are marked by the corresponding warning labels.

## General instrument information

The miniRaman spectrometer uses a laser with 660 and/or 785nm wavelength. The laser diodes used in the spectrometer emit continuous visible and partially visible laser radiation in the near infrared region.

According to the standard EN 60825-1:2014, miniRaman spectrometer is Class 3B laser product. Therefore, it is normally hazardous under direct beam viewing conditions but is normally safe when viewing diffuse reflections.

## Safety Instructions

In addition to the safety instructions given below, one should also comply with all local regulations concerning laser safety.

The analysis system is specified as a laser Class 3B product, i.e. it is considered safe if handled carefully, with restricted beam viewing. It is advised that laser safety goggles that meet the specifications for the laser your system uses are worn by the user and others within the vicinity. Laser glasses should have an LB rating above 3 for code D.

### Warning



Avoid eye and skin exposure to direct or scattered laser radiation under all circumstances! Failure to do so can cause permanent and irreversible eye damage and/or serious skin injuries!

Below is a table of the nominal ocular hazard distance (NOHD) values for the notable configurations at maximum laser power.

**Table 3.** NOHD values for the mRs spectrometer standard configuration with different laser configurations (columns) using different probes (rows) at max laser power. Note that the actual maximum laser power of the instrument may differ from these values.

mRs wavelength	660 nm	785 nm
Maximum power	80 mW	50 mW
Long WD	0.59 m	0.94 m
Mid WD	0.24 m	0.38 m
Contact 2	0.04 m	0.04 m
Contact 3	0.04 m	0.04 m
Contact 4	0.04 m	0.04 m
10x objective	0.26 m	0.42 m
20x objective	0.09 m	0.13 m
50x objective	0.25 m	0.4 m
100x objective	0.05 m	0.06 m
100x NIR objective	0.06 m	0.07 m

## Installation

### Scope of Delivery

#### Standard Components

- miniRaman spectrometer (including user manual and quality test report)
- Accessories (includes spares, adaptors, objective lenses, sample preparation tools etc.) typically:
  - Universal, middle or long distance probe
  - Calibration tool
  - Laser safety goggles
- USB-C cable

#### Inspecting the Packaging

After having received the miniRaman spectrometer, inspect the packaging for damages. If there are any signs of damage, contact your local shipping representative before opening the shipping box.

#### Warning



Do not put the miniRaman spectrometer into operation if there are signs of damage. Failure to do so may result in severe personal injuries and/or property damage.

#### Transportation

When transporting the spectrometer, use the original case to avoid damages.



**Figure 3.** Transportation case for miniRaman spectrometer.

## Site requirements

### *Space Requirements*

miniRaman spectrometer requires a space of 20 cm<sup>2</sup> benchtop space. (For the exact instrument dimensions refer to Specification.) At the rear instrument side, take a clearance of at least 3cm into account.

### *Environmental Requirements*

To ensure optimal instrument performance and long-term reliability the following environmental conditions are essential:

- Ambient temperature range: 18 - 35°C (64 - 95°F)
- Humidity (non-condensing): ≤ 70% (relative humidity)



#### **Note**



miniRaman spectrometer is an instrument of protection class I (electrical safety).



## Accessories





One will receive in the package a set of accessories. Depending on the order each accessory is recommended to be used for a particular type of measurement and test.

The probes for contact and non-contact measurements should be oriented by the upper side as shown in Table 4.

**Table 4.** Accessories for Lightnovo spectrometers

Accessory	Description	Type of measurement and test
	Long distance probe, NA=0.1, WD=0-25mm	Liquids in glass bottles, vials
	Middle distance probe, NA=0.2, WD=0-10mm	Liquids in glass bottles, vials

	<p>Contact sapphire probe - (NA=0.64, WD=0-20µm depth of focus)</p>	<p>Powders in plastic bags, solids, for tissue and scattering media</p>
	<p>Contact sapphire probe- fixed (NA=0.64, WD=40-60µm depth of focus)</p>	
	<p>Contact sapphire probe- fixed (NA=0.64, WD=80-100µm depth of focus)</p>	
	<p>Contact sapphire probe- adjustable (NA=0.64, WD=0-2500µm)</p> <p>It can be adjusted manually by using the LN probe tool delivered with the spectrometer. The adjustment is done by connecting the spectrometer to Miraspec and checking the signal after each adjustment</p>	
	<p>Short distance probe (without sapphire), adjustable NA=0.64, WD=0-2500µm</p> <p>It can be adjusted manually by using the LN probe tool delivered with the spectrometer. The adjustment is done by connecting the spectrometer to Miraspec and checking the signal after each adjustment</p>	<p>Powders in plastic bags, solids, for tissue and scattering media</p>

	<p>Universal probe (middle distance probe + fused silica glass), NA=0.2, WD=0-10mm</p>	<p>Liquids in glass bottles, vials</p>
	<p>Variable contact probe WD=0-300mm</p>	<p>Skin Powders in plastic bags Multi-layer polymers Minerals</p>
	<p>Calibration tool with polystyrene</p>	<p>Checking laser performance</p>
	<p>Silicone probe cover</p>	<p>Protects against environmental light</p>
	<p>Disposable silicone probe covers</p>	<p>Protect contact probe from contamination by sample</p>

## Software installation

1. Download Miraspec software package from the Lightnovo website:  
<https://lightnovo.com/miraspec/>
2. Open the manual inside for detailed installation and instrument connection instructions.

## Operation

### Attaching & removing probes

To attach a probe, align the bottom of the probe with the flange on the laser port.



Rotate the probe clockwise until the base is flush with the lip of the flange.



To remove the probe, grab the base of the probe and rotate anti-clockwise.



## Standalone operation

To start the instrument push and release the button on the front side for 1 second until the amber LED will light up.



Wait for about 25 seconds the screen will light up.

Most instruments have a preinstalled password (1111) for laser safety.

Follow instruction on the screen to introduce the password.



The menu will be displayed.

Confirm the details displayed are appropriate for your sample.



When the LED indicator will blink blue, now the instrument is ready for operation.



Briefly push the button once again to start the laser. The LED indicator will light up red.



Place the sample in the laser beam. Live spectrum of the sample will be displayed on the screen.



Briefly push the button one more time, the scan will start.



After the scan the instrument display will automatically show the best match, if case spectral libraries are embedded on the instrument's software.



In order to switch off the instrument push and hold the button until the LED indicator lights up amber.



Release the button, the instrument should automatically switch off.



## LED guide

### Amber

The system is loading or ready to turn On and /or Off.



### Blue

The system is ready for use and laser is off.

The LED is linking when in standalone mode.

The LED will show a solid light when connected to a computer/device.



### Red

The laser is on.



### Purple

The firmware read failure.

The instrument needs disconnecting and rebooting.



## Hardware connection

To connect the instrument to a computer, turn on the instrument.



Plug the USB-C cable into the USB-C port on the bottom of the instrument.



Plug the other end of the USB-C cable into the computer USB port.



Open the Lightnovo software on the computer.



Press the connect button on the software to begin communication with the instrument. (see software manual for details).



# Technical drawings

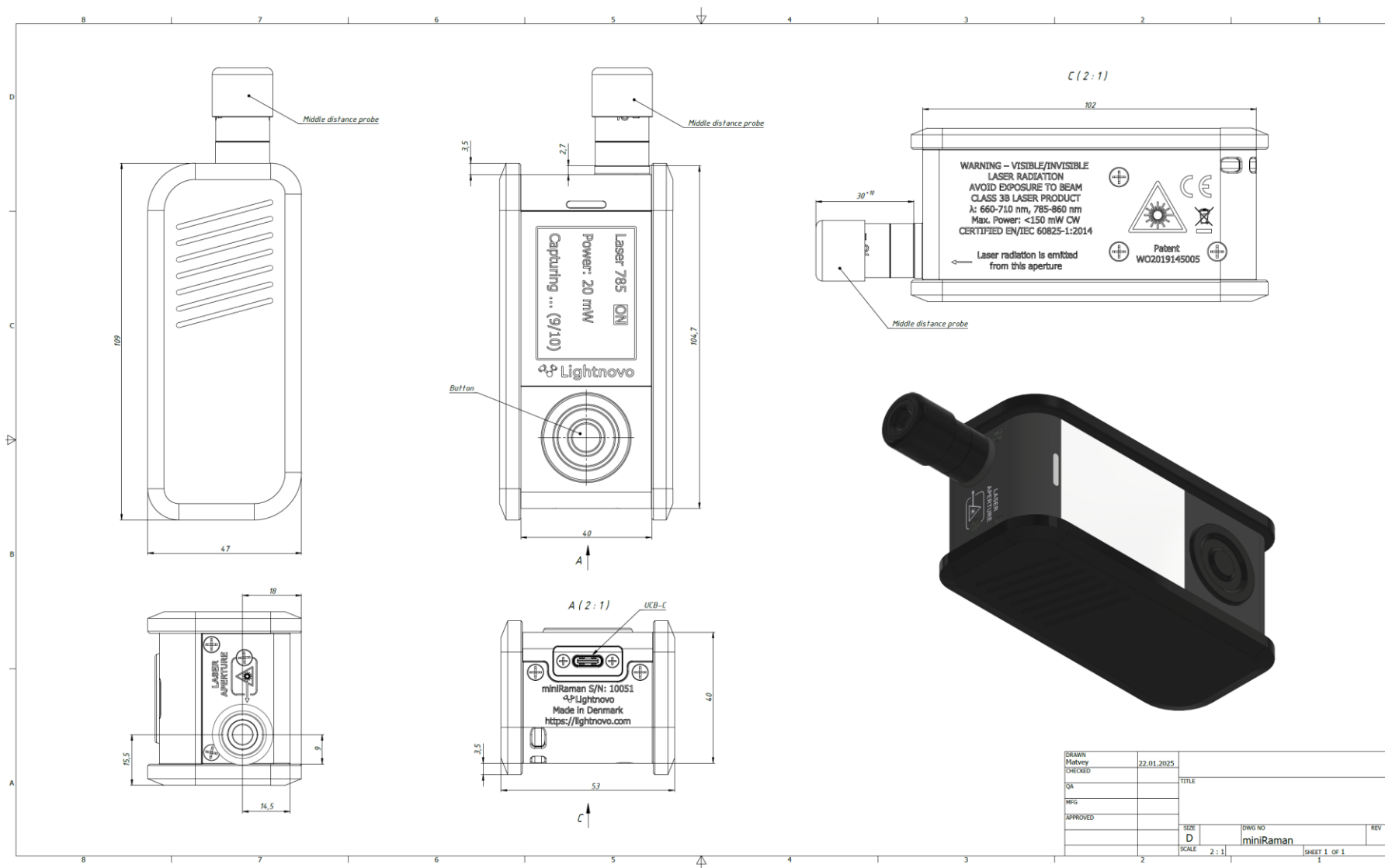

**Figure 4.** miniRaman spectrometer drawing with dimensions

# Service

## Recommended care

### *Switching the system ON/OFF*

When the instrument is not used for a longer period of time, it is highly recommended to switch off the Raman excitation laser. This action will prolong the service lifetime of the laser.

### **Warning**



Do not work with the miniRaman spectrometer at laser power that is higher than specified for the particular model. This could lead to the decreased life time of the laser diode or laser damage.

## Addresses

### **Lightnovo ApS**

Blokken 11, 1.

3460 Birkerød

Denmark

Phone: +45 71465729

<https://lightnovo.com/>

[service@lightnovo.com](mailto:service@lightnovo.com)



[lightnovo.com](http://lightnovo.com)